

## ■ Features

- $V_{DS} (V) = -30V$
- $I_D = -5.3 A (V_{GS} = -10V)$
- $R_{DS(ON)} < 50m\Omega (V_{GS} = -10V)$
- $R_{DS(ON)} < 80m\Omega (V_{GS} = -4.5V)$
- Fast switching speed

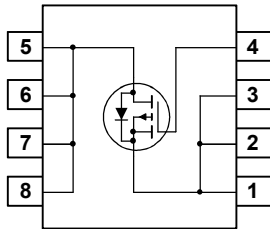

SOP-8

Unit: mm

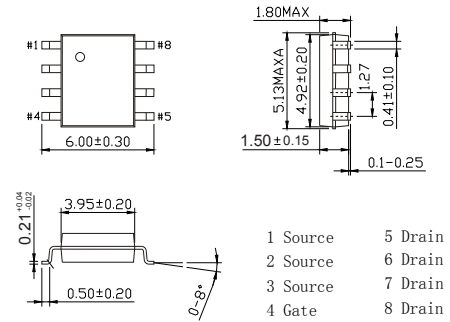

## ■ Absolute Maximum Ratings $T_a = 25^\circ C$

Parameter	Symbol	Rating	Unit
Drain-Source Voltage	$V_{DS}$	-30	V
Gate-Source Voltage	$V_{GS}$	$\pm 20$	
Continuous Drain Current	$I_D$	-5.3	A
Pulsed Drain Current	$I_{DM}$	-20	
Power Dissipation (Note.1) (Note.2) (Note.3)	$P_D$	2.5	W
		1.2	
		1	
Thermal Resistance.Junction- to-Ambient	$R_{thJA}$	50	$^\circ C/W$
Thermal Resistance.Junction- to-Case	$R_{thJC}$	25	
Junction Temperature	$T_J$	150	$^\circ C$
Junction Storage Temperature Range	$T_{stg}$	-55 to 150	

Note.1:  $50^\circ C/W$  when mounted on a  $1in^2$  pad of 2 oz copper

Note.2:  $105^\circ C/W$  when mounted on a  $.04in^2$  pad of 2 oz copper

Note.3:  $125^\circ C/W$  when mounted on a minimum pad.

■ Electrical Characteristics Ta = 25°C

Parameter	Symbol	Test Conditions	Min	Typ	Max	Unit
Drain-Source Breakdown Voltage	V <sub>DSS</sub>	I <sub>D</sub> =-250 μA, V <sub>GS</sub> =0V	-30			V
Zero Gate Voltage Drain Current	I <sub>DSS</sub>	V <sub>DS</sub> =-24V, V <sub>GS</sub> =0V			-1	μA
Gate-Body leakage current	I <sub>GSS</sub>	V <sub>DS</sub> =0V, V <sub>GS</sub> =±20V			±100	nA
Gate Threshold Voltage	V <sub>GS(th)</sub>	V <sub>DS</sub> =V <sub>GS</sub> I <sub>D</sub> =-250 μA	-1		-3	V
Static Drain-Source On-Resistance	R <sub>DS(on)</sub>	V <sub>GS</sub> =-10V, I <sub>D</sub> =-5.3A (Note.1)			50	mΩ
		V <sub>GS</sub> =-10V, I <sub>D</sub> =-5.3A, T <sub>J</sub> =125°C (Note.1)			79	
		V <sub>GS</sub> =-4.5V, I <sub>D</sub> =-4.2A (Note.1)			80	
On state drain current	I <sub>D(on)</sub>	V <sub>GS</sub> =-10V, V <sub>DS</sub> =-5V (Note.1)	-20			A
Forward Transconductance	g <sub>FS</sub>	V <sub>DS</sub> =-15V, I <sub>D</sub> =-5.3A (Note.1)		12		S
Input Capacitance	C <sub>iss</sub>	V <sub>GS</sub> =0V, V <sub>DS</sub> =-15V, f=1MHz		690		pF
Output Capacitance	C <sub>oss</sub>			306		
Reverse Transfer Capacitance	C <sub>rss</sub>			77		
Total Gate Charge	Q <sub>g</sub>	V <sub>GS</sub> =-15V, V <sub>DS</sub> =-10V, I <sub>D</sub> =-5.3A		14	23	nC
Gate Source Charge	Q <sub>gs</sub>			2.4		
Gate Drain Charge	Q <sub>gd</sub>			4.8		
Turn-On DelayTime	t <sub>d(on)</sub>	V <sub>GS</sub> =-10V, V <sub>DS</sub> =-15V, I <sub>D</sub> =-1A, R <sub>G</sub> =6Ω		7	14	ns
Turn-On Rise Time	t <sub>r</sub>			10	18	
Turn-Off DelayTime	t <sub>d(off)</sub>			19	34	
Turn-Off Fall Time	t <sub>f</sub>			11	20	
Maximum Body-Diode Continuous Current	I <sub>S</sub>				-5.3	A
Diode Forward Voltage	V <sub>SD</sub>	I <sub>S</sub> =-5.3A, V <sub>GS</sub> =0V (Note.1)			-1.2	V

Note.1: Pulse Test: Pulse Width < 300μs, Duty Cycle < 2.0%

## Typical Characteristics

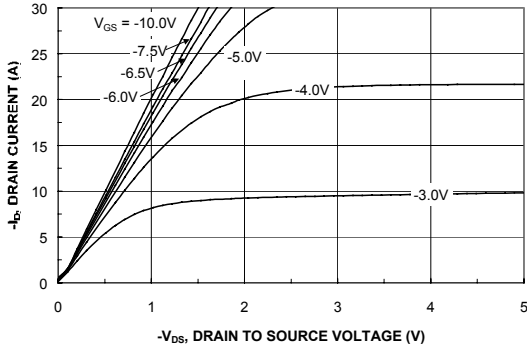

Figure 1. On-Region Characteristics.

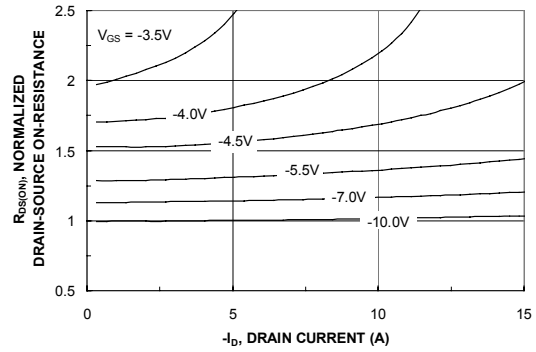

Figure 2. On-Resistance Variation with Drain Current and Gate Voltage.

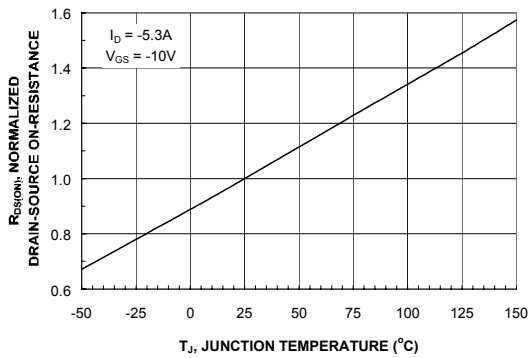

Figure 3. On-Resistance Variation with Temperature.

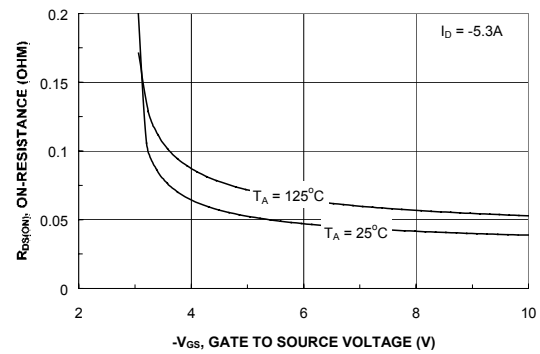

Figure 4. On-Resistance Variation with Gate-to-Source Voltage.

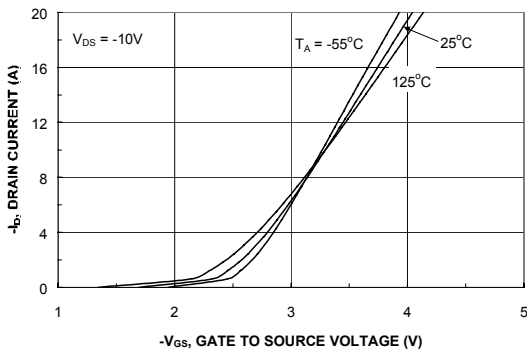

Figure 5. Transfer Characteristics.

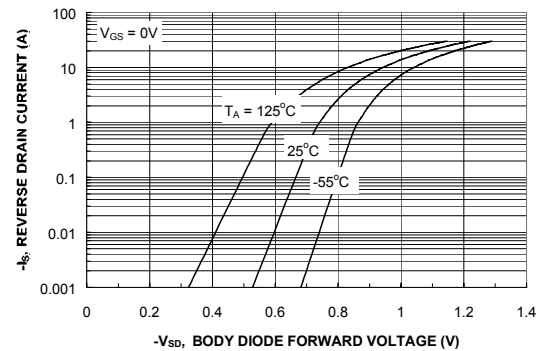

Figure 6. Body Diode Forward Voltage Variation with Source Current and Temperature.

## Typical Characteristics

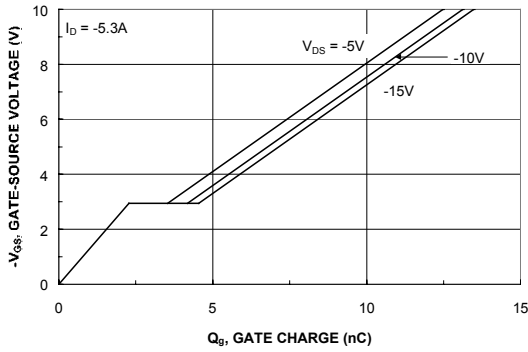

Figure 7. Gate Charge Characteristics.

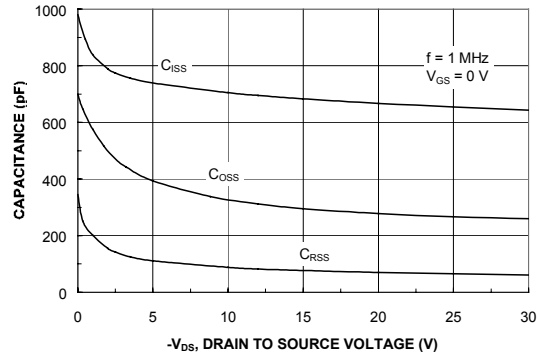

Figure 8. Capacitance Characteristics.

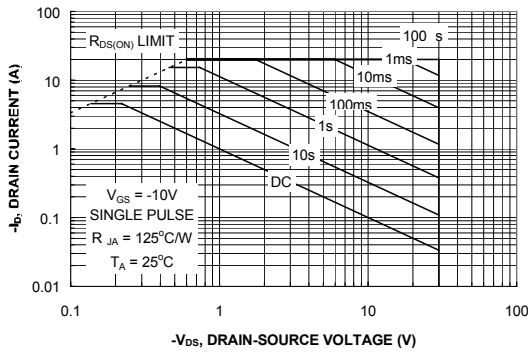

Figure 9. Maximum Safe Operating Area.

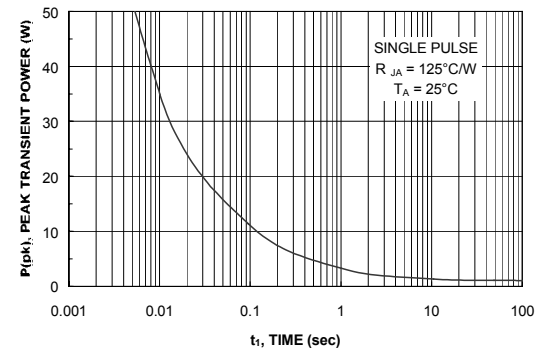

Figure 10. Single Pulse Maximum Power Dissipation.

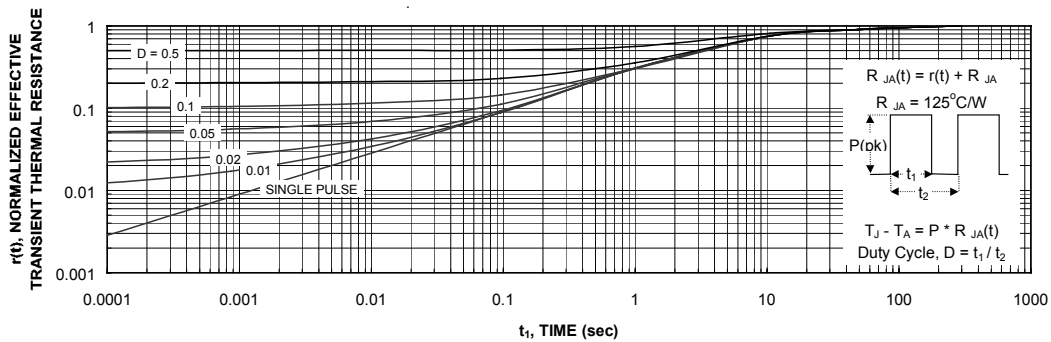

Figure 11. Transient Thermal Response Curve.

Thermal characterization performed using the conditions described in Note 1c.  
Transient thermal response will change depending on the circuit board design.