

Features

- N-Channel, Low $R_{DS(on)}$ @ $V_{GS}=10V$
- 10V Logic Level Control
- 100% UIS Tested
- Pb-Free, RoHS Compliant

$V_{(BR)DSS}$	$R_{DS(ON)}$ Typ	I_D Max
100V	90mΩ @ 10V	15A
	95mΩ @ 5V	

Applications

- Primary Side Switch
- Load Switch
- Optimized for Power Management Applications for Portable Products, such as H-bridge, Inverters Car Charger and Others

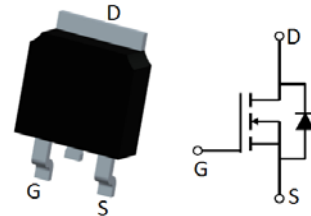

Order Information

TO-252

Product	Package	Marking	Packing	Min Unit Quantity
DWD15N10	TO-252	15N10	2500PCS/Reel	5000PCS

Absolute Maximum Ratings

Stresses exceeding Maximum Ratings may damage the device. Maximum Ratings are stress ratings only. Functional operation above the Recommended Operating Conditions is not implied. Extended exposure to stresses above the Recommended Operating Conditions may affect device reliability.

Symbol	Parameter	Rating	Unit
Common Ratings ($T_j=25^\circ\text{C}$ Unless Otherwise Noted)			
V_{GS}	Gate-Source Voltage	±20	V
$V_{(BR)DSS}$	Drain-Source Breakdown Voltage	100	V
T_j	Maximum Junction Temperature	175	°C
T_{STG}	Storage Temperature Range	-50 to 150	°C
Mounted on Large Heat Sink			
I_{DM}	Pulse Drain Current Tested①	$T_C=25^\circ\text{C}$	35 A
I_S	Diode continuous forward current	$T_C=25^\circ\text{C}$	15 A
I_D	Continuous Drain Current($V_{GS}=10V$)	$T_C=25^\circ\text{C}$	15 A
		$T_C=70^\circ\text{C}$	12 A
P_D	Maximum Power Dissipation	$T_C=25^\circ\text{C}$	50 W
EAS	Avalanche energy, single pulsed ②		21.6 mJ
$R_{\theta JC}$	Thermal Resistance-Junction to Case		3 °C/W

Symbol	Parameter	Condition	Min	Typ	Max	Unit
Static Electrical Characteristics @ T_J = 25°C (unless otherwise stated)						
V _{(BR)DSS}	Drain-Source Breakdown Voltage	V _{GS} =0V I _D =250μA	100	--	--	V
I _{DSS}	Zero Gate Voltage Drain Current(T _c =25°C)	V _{DS} =100V, V _{GS} =0V	--	--	1	μA
	Zero Gate Voltage Drain Current(T _c =125°C)	V _{DS} =80V, V _{GS} =0V	--	--	100	μA
I _{GSS}	Gate-Body Leakage Current	V _{GS} =±20V, V _{DS} =0V	--	--	±100	nA
V _{GS(TH)}	Gate Threshold Voltage	V _{DS} =V _{GS} , I _D =250μA	1.0	2.0	3.0	V
R _{DS(ON)}	Drain-Source On-State Resistance ^③	V _{GS} =10V, I _D =12A	--	90	105	mΩ
R _{DS(ON)}	Drain-Source On-State Resistance ^③	V _{GS} =5V, I _D =8A	--	95	140	mΩ
Dynamic Electrical Characteristics @ T_J = 25°C (unless otherwise stated)						
C _{iss}	Input Capacitance	V _{DS} =50V, V _{GS} =0V, f=1MHz	--	605	--	pF
C _{oss}	Output Capacitance		--	33	--	pF
C _{rss}	Reverse Transfer Capacitance		--	27	--	pF
R _g	Gate Resistance	f=1MHz	--	6.5	--	Ω
Q _g	Total Gate Charge	V _{DS} =50V I _D =5A, V _{GS} =10V	--	16.1	--	nC
Q _{gs}	Gate Source Charge		--	1.6	--	nC
Q _{gd}	Gate Drain Charge		--	4.8	--	nC
Switching Characteristics @ T_J = 25°C (unless otherwise stated)						
t _{d(on)}	Turn on Delay Time	V _{DD} =25V, I _D =8A, R _G =1Ω, V _{GS} =10V	--	14.2	--	ns
t _r	Turn on Rise Time		--	34	--	ns
t _{d(off)}	Turn Off Delay Time		--	40.4	--	ns
t _f	Turn Off Fall Time		--	6	--	ns
Source Drain Diode Characteristics @ T_J = 25°C (unless otherwise stated)						
t _{rr}	Reverse Recovery Time	I _{SD} =5A, V _{GS} =0V di/dt=100A/μs	--	35	--	nS
Q _{rr}	Reverse Recovery Charge		--	121	--	nC
V _{SD}	Forward on voltage ^②	I _{SD} =12A, V _{GS} =0V	--	0.93	1.2	V

Notes: ① Pulse width limited by maximum allowable junction temperature

② Limited by T_{Jmax}, starting T_J = 25°C, L = 0.3mH, R_G = 25Ω, I_{AS} = 12A, V_{GS} = 10V. Part not recommended for use above this value

③ Pulse width ≤ 300μs; duty cycles ≤ 2%.

Typical Characteristics

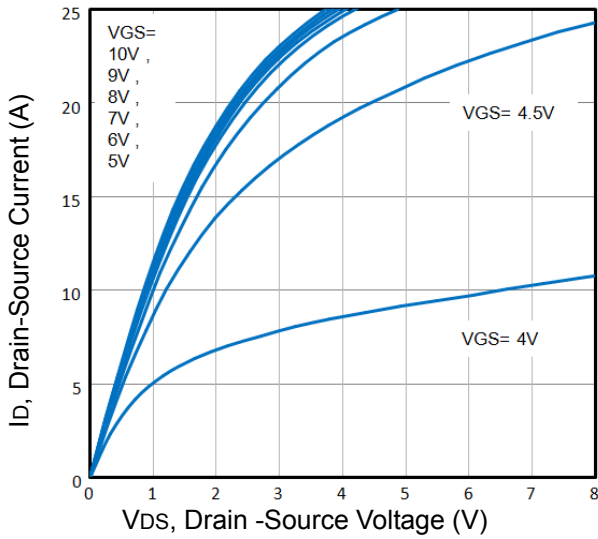

Fig1. Typical Output Characteristics

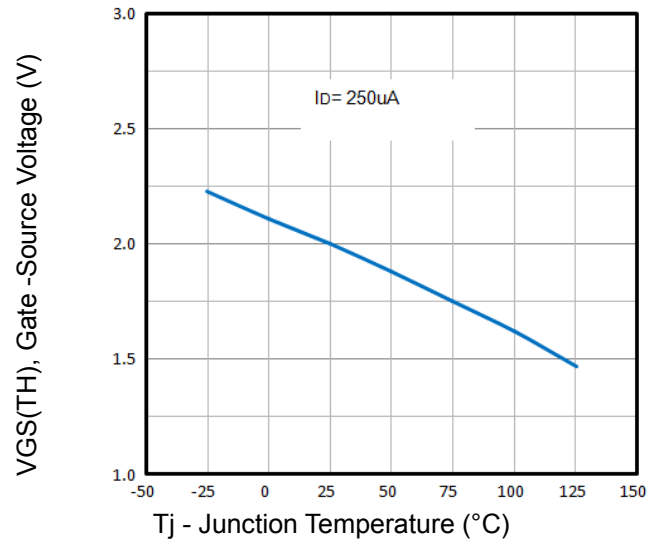

Fig2. VGS(TH) Voltage Vs. Temperature

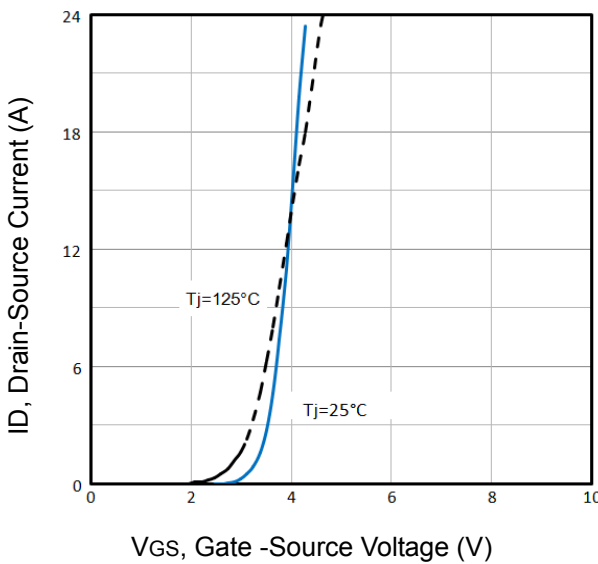

Fig3. Typical Transfer Characteristics

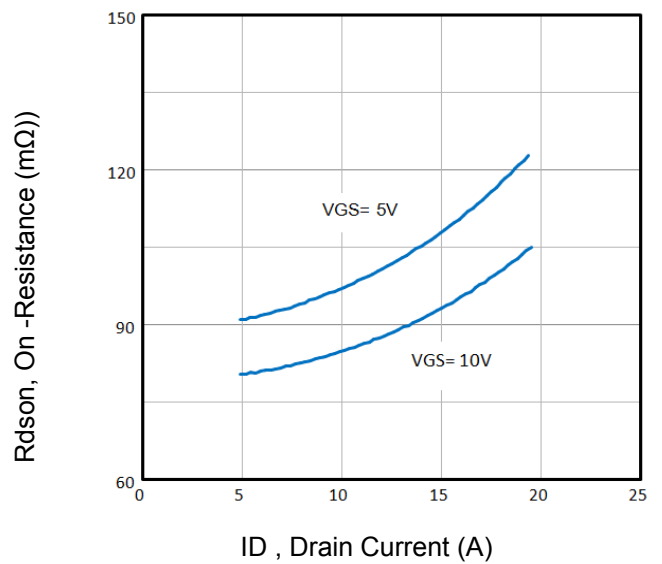

Fig4. On-Resistance vs. Drain Current and Gate Voltage

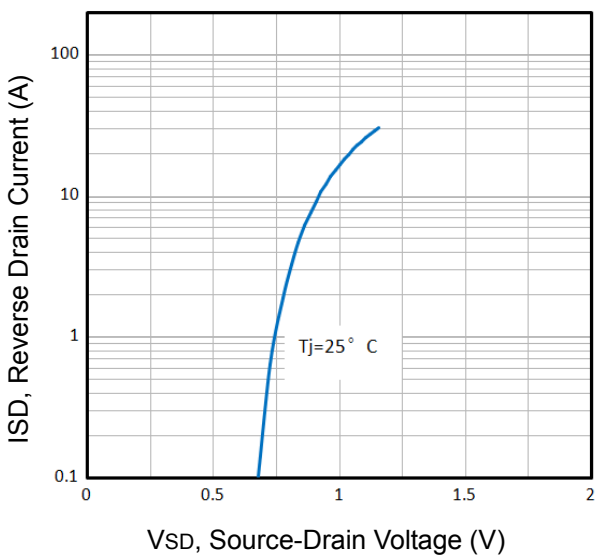

Fig5. Typical Source-Drain Diode Forward Voltage

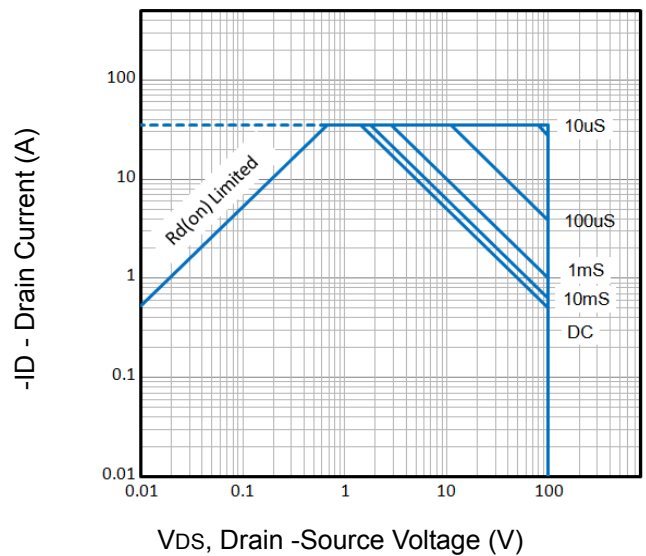

Fig6. Maximum Safe Operating Area

Typical Characteristics

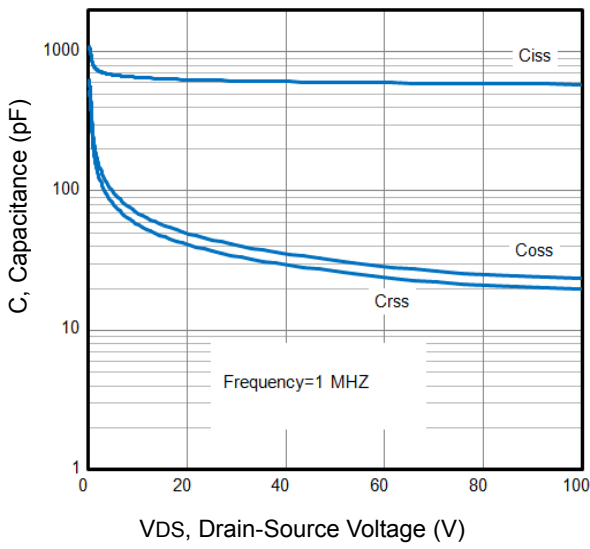

Fig7. Typical Capacitance Vs. Drain-Source Voltage

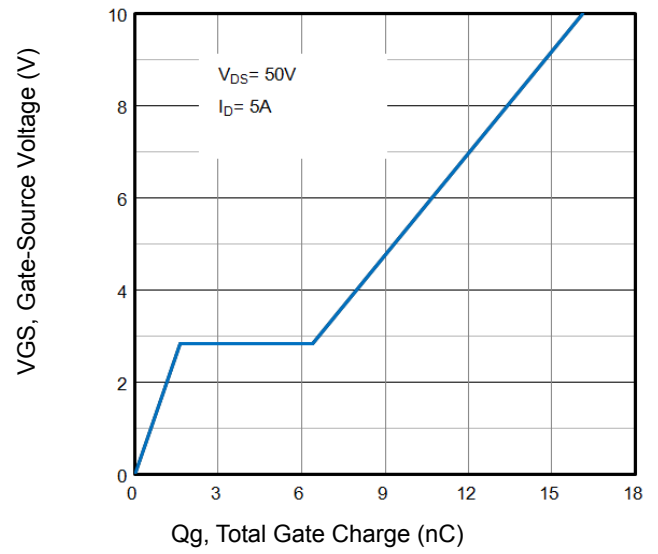

Fig8. Typical Gate Charge Vs. Gate-Source Voltage

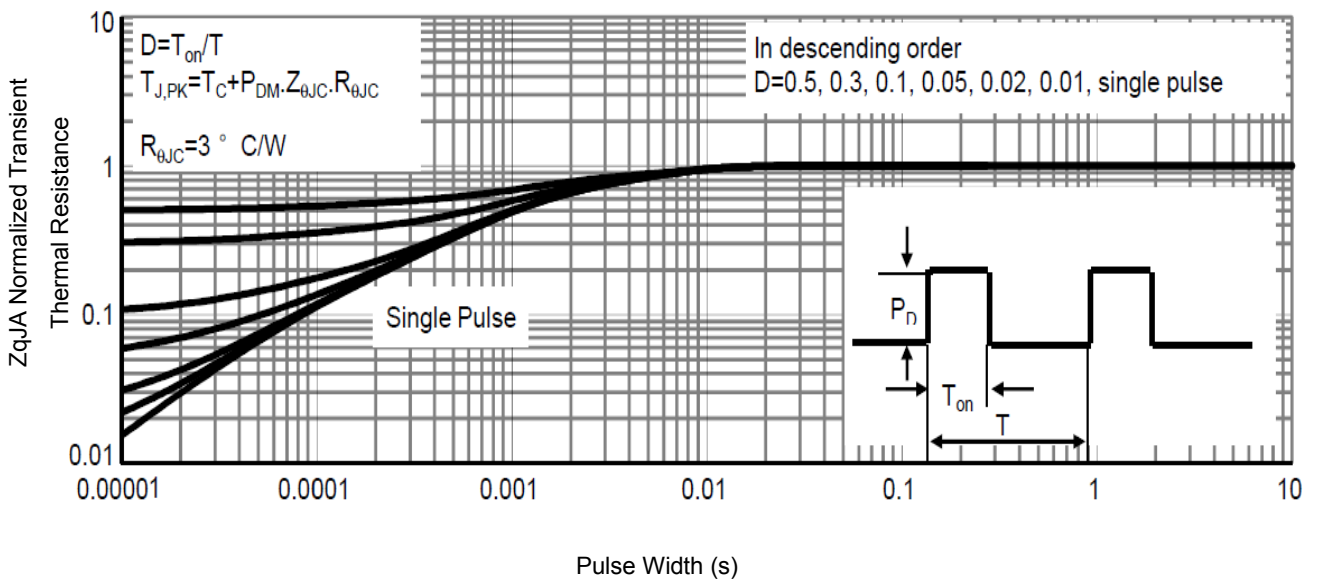

Fig9. Normalized Maximum Transient Thermal Impedance

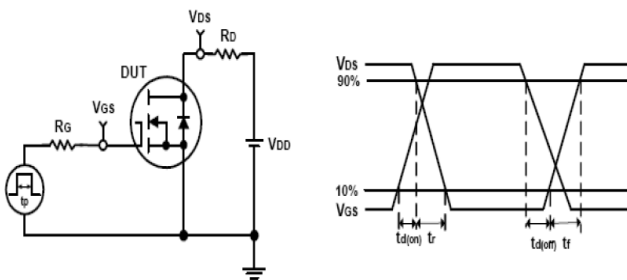

Fig10. Switching Time Test Circuit and waveforms

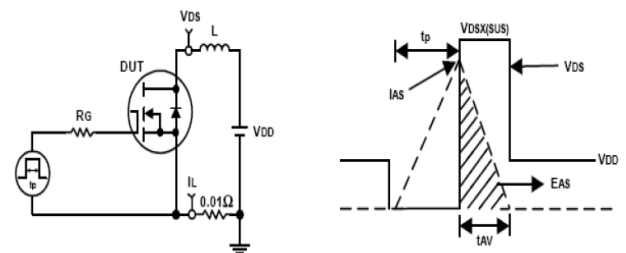
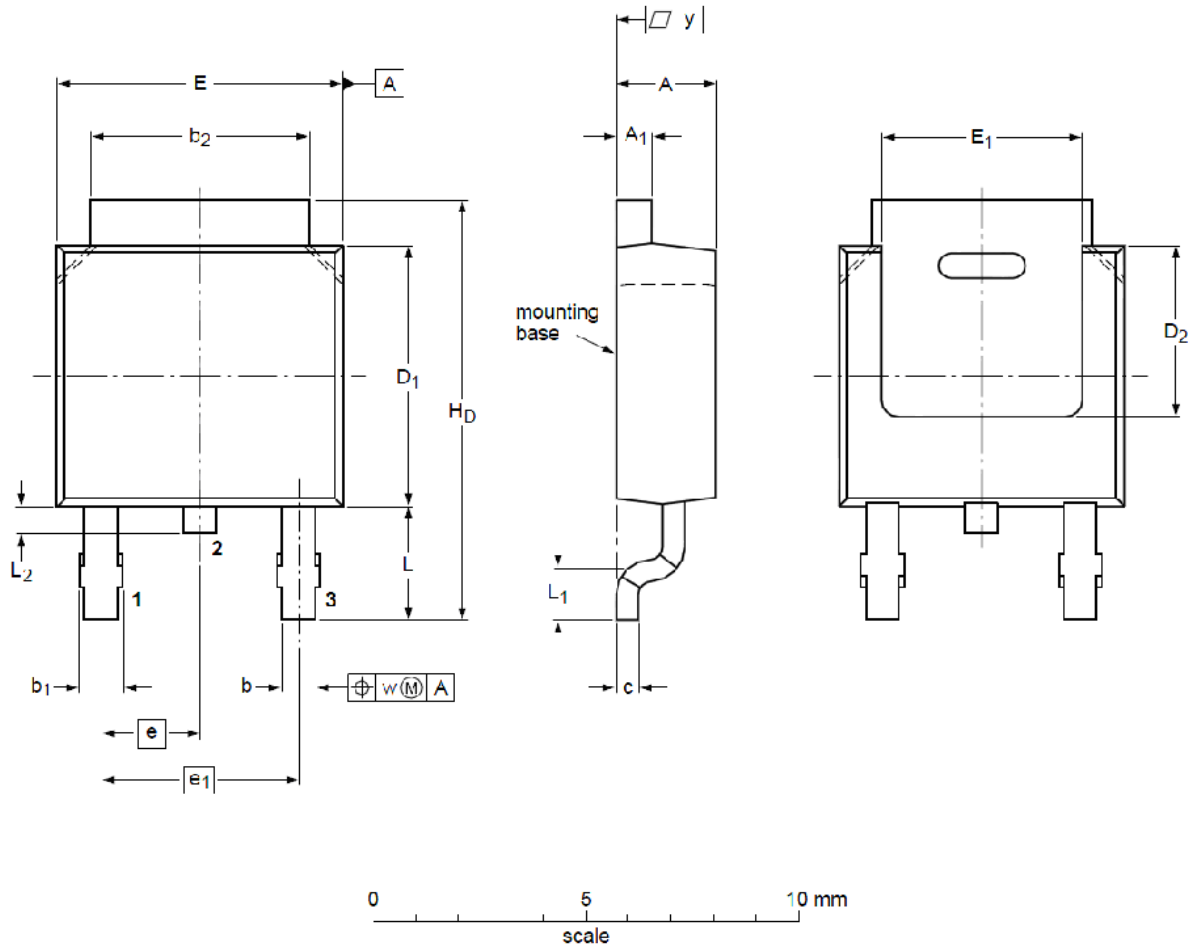

Fig11. Unclamped Inductive Test Circuit and waveforms

TO-252 Mechanical Data



DIMENSIONS (unit : mm)

Symbol	Min	Typ	Max	Symbol	Min	Typ	Max
A	2.22	2.30	2.38	A ₁	0.4	0.53	0.65
b	0.68	0.78	0.89	b ₁	0.90	0.98	1.10
b ₂	5.20	5.33	5.55	c	0.45	0.5	0.55
D ₁	5.98	6.10	6.22	D ₂	--	4.00	--
E	6.47	6.60	6.73	E ₁	5.10	5.28	5.45
e	--	2.28	--	e ₁	--	4.57	--
H _D	9.60	10.08	10.40	L	2.75	2.95	3.05
L ₁	--	0.50	--	L ₂	0.50	--	1.10
w	--	0.20	--	y	0.20	--	--